

ECO	REV	DESCRIPTION	DATE
10180	D	KNURL DIMN & ANGULARITY ADDED; TOLERANCE ADJUSTED	10-Apr-2014

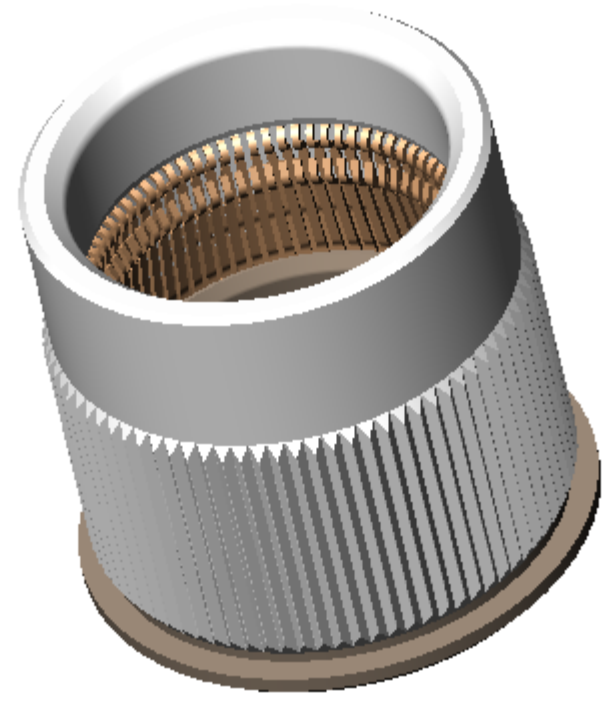
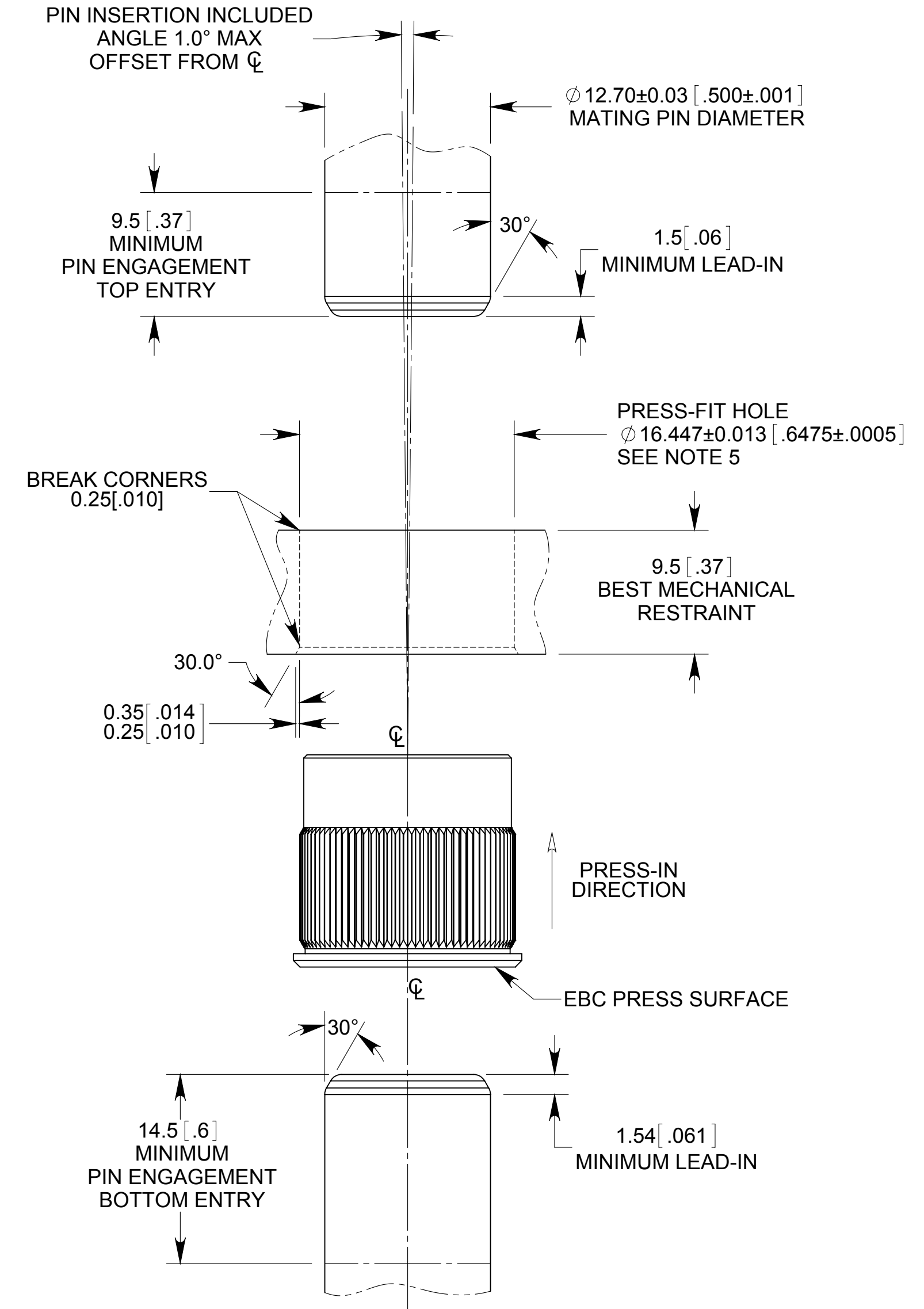
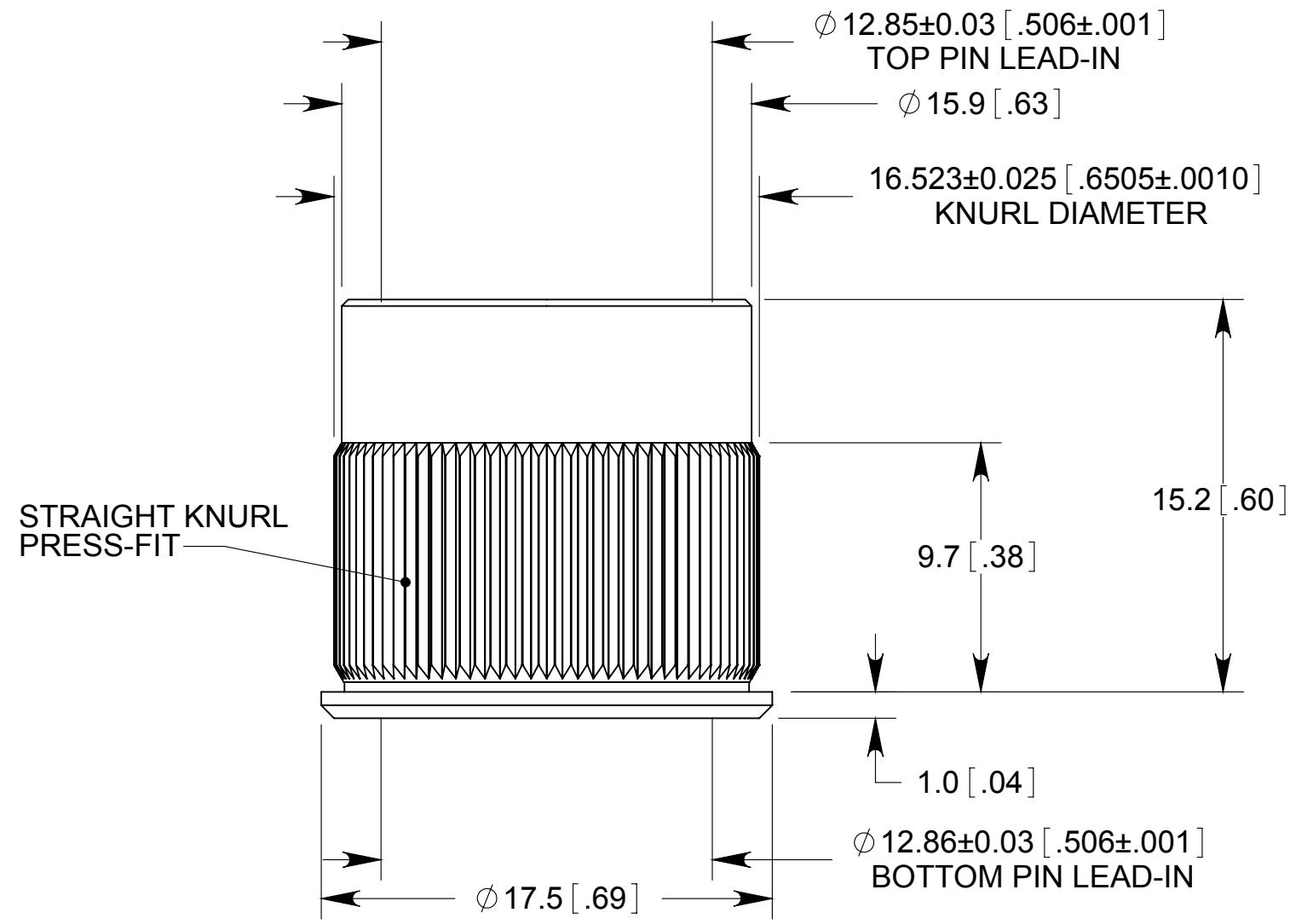

EBC 12.7 MM PB SOCKET  
PN: 1101-07083-01104

**NOTES:** UNLESS OTHERWISE SPECIFIED

- CONTACT NAME AND PART NUMBER:  
NAME: EBC CONNECTOR, SOCKET SIZE 12.7 MM  
PART NUMBER: 1101-07083-01104
- MATERIALS:  
SOCKET CONTACTS: COPPER ALLOY  
SOCKET BODY: COPPER ALLOY  
FLANGE / FERRULE: STAINLESS STEEL
- FINISHES:  
SOCKET CONTACTS: SILVER PLATING OVER NICKEL UNDER PLATING  
SOCKET BODY: SILVER PLATING OVER NICKEL UNDER PLATING
- REFERENCE DIMENSIONS IN PARENTHESIS (X.XX) ARE WITHOUT TOLERANCE AND USED FOR INFORMATION ONLY.
- PRESS-FIT HOLE DIMENSION SHOWN PROVIDES A 0.08 MM [.003"] NOMINAL DIAMETER INTERFERENCE FOR USE IN SOLID COPPER INSTALLATIONS ONLY. THESE VALUES ARE GUIDELINES. ACTUAL CONDUCTOR THICKNESS HOLE DIAMETER AND LEAD IN SHOULD BE CHARACTERISED BY THE USER FOR THEIR PARTICULAR APPLICATION.

THIRD ANGLE PROJECTION		NAME	DATE	<b>METHODE ELECTRONICS, INC.</b> <b>POWER SOLUTIONS GROUP</b> 1750 Junction Avenue, San Jose, CA 95112 (408) 453-9500								
<b>TOLERANCES</b> UNLESS OTHERWISE SPECIFIED DIMENSIONS ARE IN MILLIMETERS TOLERANCES ARE:  <table border="0"> <tr> <td><b>DECIMALS</b></td> <td><b>ANGLES</b></td> </tr> <tr> <td>X.X ± 0.2</td> <td>± 2.0</td> </tr> <tr> <td>X.XX ± 0.08</td> <td></td> </tr> <tr> <td>X.XXX ± 0.013</td> <td></td> </tr> </table>		<b>DECIMALS</b>	<b>ANGLES</b>		X.X ± 0.2	± 2.0	X.XX ± 0.08		X.XXX ± 0.013		ORIG: R. Larsen	12/16/2010
		<b>DECIMALS</b>	<b>ANGLES</b>									
		X.X ± 0.2	± 2.0									
X.XX ± 0.08												
X.XXX ± 0.013												
ENGR: R. Larsen	12/16/2010											
<b>SURFACE FINISH:</b> N/A		CHECKED: H. Han	12/16/2010									
		<b>PROPRIETARY AND CONFIDENTIAL NOTICE</b> ALL INFORMATION IN THIS DRAWING IS CONFIDENTIAL AND PROPRIETARY INFORMATION AND IS NOT TO BE DISTRIBUTED, COPIED, OR SHARED EXCEPT WITH PRIOR WRITTEN APPROVAL OF METHODE ELECTRONICS, INC. POWER SOLUTIONS GROUP.										
		SIZE: <b>C</b>	DRAWING NUMBER: <b>C1101-07083-01104</b>	REV: <b>D</b>								
		SCALE: 4:1	FILENAME: 1101-07083-01104	SHEET 1 OF 1								

**TITLE: USER DRAWING, EBC CONNECTOR  
SIZE 12.7 MM  
STRAIGHT KNURL**